



LD-G-30

Art.-Nr. 41-0130x



LD-G-31

Art.-Nr. 41-0131x



LD-G-32

Art.-Nr. 41-0132x



LD-G-33

Art.-Nr. 41-0133x



LD-G-34

Art.-Nr. 41-0134x

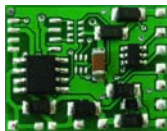

LD-W-32

Art.-Nr. 41-0232x



LD-W-33

Art.-Nr. 41-0233x



Manual

Mode d'emploi



-
-
-
- English 3
- Français 47
-
-

© 09/2009 Tams Elektronik GmbH
All rights reserved. No part of this publication may be reproduced or transmitted in any form or by any means, electronic or mechanical, including photocopying, without prior permission in writing from Tams Elektronik GmbH.
Subject to technical modification.

© 09/2009 Tams Elektronik GmbH
Tout droits réservés, en particulier les droits de reproduction et de diffusion ainsi que le traduction. Toute duplication ou reproduction sous quelque forme que ce soit nécessite l'accord écrit de la société Tams Elektronik GmbH.
Sous réserve de modifications techniques.

-
-
-
-
-
-
-
-
-

Table of contents

1. Getting started	4
2. Safety instructions	6
3. Safe and correct soldering	8
4. Operation overview	9
5. Technical specifications	16
6. Mounting the locomotive decoder	17
7. Programming the locomotive decoder	22
8. Configuration variables and the registers	25
9. Check list for trouble shooting	43
10. CE and Warranty	44

Connection diagramms

LD-G-30	I
LD-G-31	II
LD-G-32 / LD-W-32	III
LD-G-33 / LD-W-33	IV
LD-G-34	V
Connection of a SUSI-module	VI

(Pages I to VI in the centre of this handbook are removeable.)

Remark: RailCom[®] is the registered trademark of the Lenz Elektronik GmbH, Hüttenbergstraße 29, D-35398 Gießen. To increase the text's readability we have refrained from referring to this point in each instance.

1. Getting started

This manual applies to all locomotive decoders of the 30s series, so for:

- locomotive decoder LD-G-30, LD-G-31, LD-G-32, LD-G-33 and LD-G-34 and
- locomotive decoder LD-W-32 and LD-W-33.

Provided there are no other details given for particular sections, the information given applies to all decoders.

How to use this manual

This manual gives step-by-step instructions for safe and correct fitting of the decoder, and operation. Before you start, we advise you to read the whole manual, particularly the chapter on safety instructions and the FAQ chapter. You will then know where to take care and how to prevent mistakes which take a lot of effort to correct.

Keep this manual safely so that you can solve problems in the future. If you pass the decoder on to another person, please pass on the manual with it.

Intended use

The locomotive decoders of the 30er series are designed for mounting in model locomotives with DC motor (LD-**G**-decoders) resp. AC motor (LD-**W**-decoders). They evaluate the Motorola or DCC format data sent by the digital central unit to their addresses and control the locomotive's motors and additional functions.

The decoders should not be mounted by children under the age of 14.

Reading, understanding and following the instructions in this manual are mandatory for the user.

Any other use is inappropriate and invalidates any guarantees.

**Caution:**

Integrated circuits (ICs) are inserted on the decoder. They are sensitive to static electricity. Do not touch components without first discharging yourself. Touching a radiator or other grounded metal part will discharge you.

Checking the package contents

Check the contents of the package for completeness after unpacking:

- one decoder, with or without soldered connecting wires resp. soldered NEM or PluX interface connector, depending on the version,
- one manual.

N.B. For technical reasons it is possible that the PCB is not completely inserted. This is not a fault.

Required tools and materials

Make sure you have the following tools and materials ready for use, if you have purchased a decoder without soldered interface connector:

- an electronic soldering iron (max. 30 Watt) with a fine tip,
- a soldering iron stand,
- a tip-cleaning sponge,
- a heat-resistant mat,
- a small side cutter, a wire stripper and a pair of tweezers,
- tin solder (0,5 mm. diameter),

In order to connect decoders without soldered connecting wires or connectors you will need wire. Recommended cross sections:

- $\geq 0,05 \text{ mm}^2$ for connections to the function outputs
- $\geq 0,05 \text{ mm}^2$ for connections to the motor (except for the LD-G-34)
- $\geq 0,14 \text{ mm}^2$ for connections to the motor of the locomotive decoder LD-G-34

2. Safety instructions

Mechanical hazards

Cut wires can have sharp ends and can cause serious injuries. Watch out for sharp edges when you pick up the PCB.

Visibly damaged parts can cause unpredictable danger. Do not use damaged parts: recycle and replace them with new ones.

Electrical hazards

- Touching powered, live components,
- touching conducting components which are live due to malfunction,
- short circuits,
- connecting the circuit to another voltage than specified,
- impermissibly high humidity,
- condensation build up

can cause serious injury due to electrical shock. Take the following precautions to prevent this danger:

- Never perform wiring on a powered decoder.
- Mounting the decoder should only be done in closed, clean, dry rooms. Beware of humidity.
- Only use low power for this decoder as described in this manual and only use certified transformers.
- Connect transformers and soldering irons only in approved mains sockets installed by an authorised electrician.
- Observe cable diameter requirements.
- After condensation build up, allow a minimum of 2 hours for dispersion.
- Use only original spare parts if you have to repair the decoder.

Fire risk

Touching flammable material with a hot soldering iron can cause fire, which can result in injury or death through burns or suffocation. Connect your soldering iron or soldering station only when actually needed. Always keep the soldering iron away from inflammable materials. Use a suitable soldering iron stand. Never leave a hot soldering iron or station unattended.

Thermal danger

A hot soldering iron or liquid solder accidentally touching your skin can cause skin burns. As a precaution:

- use a heat-resistant mat during soldering,
- always put the hot soldering iron in the soldering iron stand,
- point the soldering iron tip carefully when soldering, and
- remove liquid solder with a thick wet rag or wet sponge from the soldering tip.

Dangerous environments

A working area that is too small or cramped is unsuitable and can cause accidents, fires and injury. Prevent this by working in a clean, dry room with enough freedom of movement.

Other dangers

Children can cause any of the accidents mentioned above because they are inattentive and not responsible enough. Children under the age of 14 should not be allowed to work with this decoder.

Little children can swallow small components with sharp edges, with fatal results! Do not allow components to reach small children.

In schools, training centres, clubs and workshops, assembly, mounting and operation must be supervised by qualified personnel.

In industrial institutions, health and safety regulations applying to electronic work must be adhered to.

3. Safe and correct soldering



Caution:

Incorrect soldering can cause dangers through fires and heat. Avoid these dangers by reading and following the directions given in the chapter **Safety instructions**.

- Use a small soldering iron with max. 30 Watt. Keep the soldering tip clean so the heat of the soldering iron is applied to the solder point effectively.
- Only use electronic tin solder with flux.
- When soldering electronic circuits never use soldering-water or soldering grease. They contain acids that can corrode components and copper tracks.
- Solder quickly: holding the iron on the joints longer than necessary can destroy components and can damage copper tracks or soldering eyes.
- Apply the soldering tip to the soldering spot in such a way that the wire and the soldering eye are heated at the same time. Simultaneously add solder (not too much). As soon as the solder becomes liquid take it away. Hold the soldering tip at the spot for a few seconds so that the solder flows into the joint, then remove the soldering iron.
- The joint should be held still for about 5 seconds after soldering.
- To make a good soldering joint you should use a clean and unoxidised soldering tip. Clean the soldering tip with a damp piece of cloth, a damp sponge or a piece of silicon cloth.
- After soldering check (preferably with a magnifying glass) tracks for accidental solder bridges and short circuits. This would cause faulty operation or, in the worst case, permanent damage. You can remove excess solder by putting a clean soldering tip on the spot. The solder will become liquid again and flow from the soldering spot to the soldering tip.

4. Operation overview

Driving in digital operation

The locomotive decoders of the 30´s series are multiple protocol decoders, that can operate with and automatically recognise both DCC or Motorola formats.

The number of addresses is dependant on the format being used.

Motorola-Format: 255 addresses.

DCC- Format: 127 Basis-addresses or 10.239 extended addresses.

In the DCC format the decoders can be driven in all speed levels (14, 28 or 128).

In the Motorola format the decoders can be driven in 14 or 27 speed levels. Driving all 27 speed levels can be done only with central units which support this mode (e.g. MasterControl). With central units which allow 14 speed levels only, it is only possible to select every second speed level.

Programming the decoders is done in DCC format by setting the configuration variables and in Motorola format through the registers.

Operation in analogue mode

The locomotive decoders of the 30´s series can also be used in analogue model railway layouts. They can be run with an A.C. speed control as well as with a D.C. speed control. When putting the vehicle on the rails the decoder recognizes automatically if it is run in analogue or digital mode and sets the corresponding operation mode. The automatic recognition of the analogue mode can be switched off.



Caution:

Old analogue driving transformers (e.g. models in a blue housing from Märklin**) are not suitable for use with digital decoders in analogue operation! These transformers have been designed for the older supply voltage of 220 V and, due to construction, generate very high excess voltage impulses when changing the driving direction. When using them

with the modern supply voltage of 230 V too high excess voltage impulses can occur, damaging electronic parts on the decoder. For that reason only use driving transformers designed for a net voltage of 230 V.

Switching the function outputs on or off is not possible in analogue mode. They can be programmed so that they are either switched on or off in analogue mode. The effects set for the outputs are active in analogue mode as well.

Outputs to be switched with F0 are switched on or off in analogue mode according to the direction of travel.

For LD-G-33 and LD-G-34 only: The decoders' load control is also active in analogue mode. The set maximum speed also limits in analogue mode the maximum speed of the locomotive.

LD-G-30, LD-G-33, LD-G-34: Overload Protection

As soon as the maximum total current of the LD-G-30, LD-G-33 or LD-G-34 is exceeded, the decoder automatically temporarily switches off the motor and the function outputs, in order to protect the decoder from overheating. This operation will be repeated until the overload has been eliminated. With the LD-G-30 and the LD-G-33 the sensitivity of the overload protection can be altered by programming a configuration variable.



Caution:

When a short circuit caused by contact between decoder and housing occurs the current as a rule is so high, that the overload protection cannot protect the decoder from being damaged.

Driving of the motor

The different decoder types are designed to optimally control their particular fitting motor types.

Decodertyp	PWM	Suitable for coreless (Faulhaber) motors
LD-G-30	32 kHz (fixed)	yes
LD-G-31	17 or 32 kHz (to be set)	yes
LD-G-32	32 kHz (fixed)	yes
LD-G-33	17 or 32 kHz (to be set)	yes
LD-G-34	17 or 32 kHz (to be set)	yes
LD-W-32	480 or 60 Hz (to be set)	no
LD-W-33	480 Hz (fixed)	no

LD-G-decoders: Load control

The LD-**G**-locomotive decoders for DC motors have a load control, the decoder LD-**W**-locomotive decoders for AC motors do not have this function. The load control influences the motor voltage to keep the locomotive at constant velocity, independent of additional loads (e.g. running up a gradient, coupled carriages).

It is possible to switch on and off the load control by varying a CV-variable of the decoder. The parameters of the load control may be altered as well, in order to adapt the decoder to the motor's individual characteristics.

Parameters of the load control: The load control is determined by three parameters which have to be coordinated in order to achieve optimal driving characteristics. Each of the load control parameters is assigned to a configuration variable. The parameters are:

KP: The proportional component of the load control ensures the difference between the set and the present value being as small as possible. It cannot have the value "0" at any time. This component affects the basic speed. In case the set value is too small the locomotive runs too slowly. In case the set value is too high the locomotive vibrates while moving.

KI: The integral component of the load control ensures the remaining difference between the set and the present value is reduced to 0 and so for the correction of very small divergences. If the set value is too high the locomotive vibrates massively while moving.

KD: The differential component of the load control ensures that the control is not converted too quickly. Is the set value too low then the locomotive vibrates. If the set value is too high, the locomotive shakes while moving.

Velocity characteristic

The decoders can be adjusted to the driving characteristics of the motor and the characteristic speed of the locomotive type, by setting the starting velocity and the maximum velocity. From the starting velocity and the maximum velocity the decoder generates a linear velocity characteristic.

When the speed level mode is set to 28 speed levels, it is possible to assign any motor voltage to all of the 28 speed levels as an alternative to the linear velocity characteristic. This allows the programming of a velocity characteristic which adjusts the individual driving characteristics of the motor. The set values are saved in the alternative velocity table.

Shunting gear

It is possible to switch into the shunting gear mode via a function key, when so programmed. In the shunting gear mode, the velocity of all speed levels is reduced to approx. 50 % compared to the set velocity.

Acceleration and brake delay

It is possible to program the acceleration and brake delay individually via the central unit. When so programmed, it can be switched on and off with the function key F3.

Emergency stop

It is possible to carry out an emergency stop at a change of direction automatically, when so programmed.

LD-G-33, LD-G-34 and LD-W-33: Slider commutation

The decoders LD-G-33, LD-G-34 and LD-W-33 have a function output to be programmed so that it switches a relay for slider commutation. Due to the principle of the slider commutation it does not work in sections switched currentless (braking sections).

Function outputs

The decoders have two, four or six function outputs depending on the type, which are available to connect optional accessories (e.g. lighting, smoke generator, sound module, electric coupling). The accessories' number and type to be connected depends on the outputs' number and maximum current as well as on the maximum total current of the special decoder (see section 5 "Technical specifications").

In DCC format the function outputs can be switched via the function keys F0 to F12. In Motorola format the function outputs can be switched via the function keys F0 to F4. The functions F5 to F9 can be switched via the function keys F1 to F4 and F0 by assigning them to a second address. The functions F10 to F12 are not available in Motorola format.

You can assign the function keys to the function outputs freely. It is possible to assign several function keys to one function output.

LD-G-31: Connections for a signal hooter

It is possible to connect a loudspeaker to the LD-G-31 (not included in the package). Via two function keys two signal hooters with different frequencies can be generated. You can assign the function keys freely.

LD-G-33, LD-G-34 and LD-W-33: SUSI interface

A SUSI module can be connected to the LD-G-33, LD-G-34 or the LD-W-33 and programmed via the decoder. It is not possible to read the SUSI module's data via the decoder.

The locomotive decoder transmits the function status and the speed level set at the central unit, to the SUSI module. This affects the SUSI module's outputs depending on the speed level (e.g. motor sound).

Effects of the function outputs

It is possible to set the following effects for all function outputs individually:

Dimming: The voltage applied to an output can be reduced by programming the decoder accordingly. Example of use: The electric bulbs of older vehicles made for analogue operation can be dimmed and thus must not be exchanged after the mounting of the decoder. In addition, it is possible to dim the voltage depending on the speed level. This enables weak smoke generation during halts or a switched off or dimmed cab lighting while the train is moving.

Flashing. Both the frequency and the keying ratio can be set. Examples of use: single and alternating flash lights or strobe lights.

Switching on and off depending on the direction of travel: Any output can be programmed to be switched on and off depending on the direction of travel.

LD-G-31, LD-G-33, LD-G-34 and LD-W-33 only: Kick function: It is possible to set the function outputs so that they get the full voltage first for up to 20 seconds and then are dimmed. Example of use: For some types of electric couplings you need the full voltage for decoupling and the voltage then reduced to protect the couplings. In addition it is possible to program the outputs so that the locomotive moves a short distance from the disengaged carriages automatically after releasing the kick function.

LD-G-31, LD-G-33, LD-G-34 and LD-W-33 only: Special function for speed level 0: It is possible to program one function to switch off other functions or switch on special function outputs at speed level 0. Example of use: In some locomotive sheds it is customary that the tail lamps of parked locomotives have to be temporarily set at the front and the back.

Feedback with RailCom

RailCom is a log for bi-directional communication in digital model railway layouts controlled in DCC-format. It allows e.g. the feedback of the address and the CV values from the decoder to the digital control unit or to special receivers (so-called detectors). The decoders must be designed to send the RailCom messages.

When so programmed, the locomotive decoders of the 30´s series send (continuously) the (basic, extended or consist) address to the detectors (so-called RailCom broadcast datagramm) and transfer a CV message after a DCC CV read-out command.

Sending RailCom messages is only possible in layouts with a DCC signal on the rails. That is the reason why it is not possible to use the RailCom-function in a pure Motorola environment, but only when at least one other locomotive or function decoder on the layout is controlled in DCC format.

5. Technical specifications

Data format	DCC and Motorola
Feedback log	RailCom
Supply voltage	12-24 Volt digital voltage or max. 16 V analogue voltage
Current consumption (without connected loads)	approx. 10 mA
Protected to	IP 00
Ambient temperature in use	0 - + 60° C
Ambient temperature in storage	-10 - + 80° C
Comparative humidity allowed	max. 85 %

Decoder type	Max. total current [mA]	Max. current for motor [mA]	Number of function outputs	Max. current per output [mA]	Dimensions of PCB approx. [mm]	Weight without cables or interface [g]
LD-G-30	700	500	2	100	12,5 x 9,3 x 2,8	0,2
LD-G-31	1.200	500	4	300	20 x 9,5 x 3,5	0,3
LD-G-32	1.500	1.000	2	300	22 x 17 x 6	1,8
LD-G-33	1.500	1.000	6	500	25,5 x 16 x 2,9	1,6
LD-G-34	3.000	3.000	6	500	26,5 x 18 x 5,5	2,4
LD-W-32	1.500	1.000	2	300	22 x 17 x 6	1,8
LD-W-33	1.500	1.000	6	500	25,5 x 16 x 2,9	1,6

6. Mounting the locomotive decoder

Caution:

Before mounting the decoder check if the maximum locomotive motor's current on-load is below the maximum permissible value. If it is above the decoder is not suitable for mounting in this locomotive. It would be damaged when put into operation or with decoders with overload protection (LD-G-30, LD-G-33 and LD-G-34) switched off.

LD-G-decoders: Using decoders with interface connectors

Many recent locomotives with d.c. motor are equipped ex works with an interface socket according to NEM 651, NEM 652 or NEM 658. The interface enables you to connect the motor to the motor, the rail current collectors, the lighting and – provided the special connector is designed for it – additional accessories.

Using a decoder with a suitable connector saves separating the connections and soldering works at the locomotive. When mounting decoders with 6-pole interface connectors according to NEM 651 or 8-pole interface connectors according to NEM 652, take care to put the markings on the connector and on the socket on top of each other. The 12-pole PluX-connectors according to NEM 658 can be mounted in one direction only.

Mounting decoders without interface connector

Open the locomotive housing. Locate the position for the decoder. Disconnect the motor from the rail current collector or the change-over switch from the motor and rails if you have a locomotive with electronic change-over switch. The change-over switch is no longer necessary, you can remove it.

Caution:

The interference suppression devices mounted to the motor or the connecting wire must not be removed! Motor and interference

suppression devices are one unit. If even one part is removed, it can cause extreme interference!

Connecting the decoder

Follow the connection diagram for the particular decoder.

Decoder for DC motors (LD-**G**-decoder): Connect the decoder to the rail current collectors and to the motor.

Decoder for AC motors (LD-**W**-decoder): Connect the decoder to the connections from the slider and the housing. These two connections can be exchanged without effecting functionality. Next connect the connections of the field coil and the connection of the motor shield to the decoder.

Should the locomotive's direction of motion in analogue mode not match the direction of motion set at the speed control you have to swap the connections to the rail current collectors / the slider.

Connecting accessories to the outputs

Before connecting the lighting and other accessories to the outputs check if the output's current is below the maximum permissible value and the total current is below the safe load (including motor current).



Caution:

Should the permissible output current is exceeded, this normally results in permanent damage to the output. Exceeding the decoder's total current will lead to damage or, with decoders with overload protection (LD-G-30, LD-G-33 and LD-G-34) to switching off the decoder.

Disconnect any existing diodes in the leads to the lamps. Connect the lamps and the accessories to the function outputs of the decoder. The assignment of the function outputs to the function keys will be made when programming the decoder.

If the lamp or the accessory is already connected with one side to vehicle ground, the connection is complete. If not, connect the second side of the lamp or the accessory to the return conductor of the decoder (point RL).

 **Caution:**

If you connect the accessories to the return conductor for all functions (point RL), the accessories must be insulated. The accessories should not make contact with metal parts of the vehicle. Possible short circuit! The decoder will be damaged in operation. The overload protection of the decoders LD-G-30, LD-G-33 and LD-G-34 cannot protect them from being so damaged.

 **Caution:**

The return conductor for all functions (point RL) must under no circumstances be connected to vehicle ground. Possible short circuit! The decoder will be damaged in operation. The overload protection of the decoders LD-G-30, LD-G-33 and LD-G-34 cannot protect them from being so damaged.

Tip: Before starting to program the locomotive decoder you should connect the motor to the decoder. Otherwise there is no confirmation signal to the (DCC-) central unit. Should you intend to program the decoder with a Motorola central unit you should always connect the lighting to the outputs, intended to connect the front and the back lighting ex works. The locomotive indicates the change-over to the programming mode and the taking-over of settings by flashing of the lighting connected to these outputs.

Connecting the LEDs

The function outputs of the decoder switch respective to the decoder ground. For that reason you must connect the cathode (-) of the LED to the function outputs.



Caution:

If you use light-emitting diodes (LEDs) you must always operate them via a series resistor. LEDs are available in many different models. The series resistor limits the current flow of the LED and will need to be calculated for each model. Ask for the max. current rating when buying your LEDs.

You can connect several LEDs in parallel to each output. In this case every LED must have a series resistor of its own. If you connect several LEDs to one output in series, only one series resistor is needed.

LD-G-31: Connecting a loudspeaker

Use a loudspeaker as large as possible with an impedance of at least 8 Ohm. Decisive for the sound reproduction is the correct mounting of the loudspeaker. The loudspeaker membrane should emit directly to the outside, the other side into the inside of the vehicle which should be as airtight as possible. If necessary, use a loudspeaker with a sound cartridge. The larger the volume in the inside, the better is the reproduction quality. Suitable for the mounting are e.g. the bottom of the vehicle or the back of the driver's cab.

Connect the loudspeaker to the points X1 and X2 of the decoder.

LD-G-33, LD-G-34 und LD-W-33: Connecting a SUSI module

The decoder has four soldering points for the connection of a SUSI module. You will find the pin connection in the connection diagram for the particular decoder.

Connecting a smoothing capacitor

In track sections with bad contacts the power supply may be interrupted shortly. With those locomotive decoders with enough space on the PCB (LD-G-32, LD-G-33, LD-G-34, LD-W-32, LD-W-33) you can solder an additional capacitor to counteract this effect (see connection diagram of the particular decoder).

Fixing the locomotive decoder

After completing all connections fix the locomotive decoder with double-sided adhesive tape, for example.

Decoder factory settings

Decoder type	Front lighting	Back lighting	Accessory switched via F1	Accessory switched via F2	switched via F3	switched via F4	Accessory switched via F5	Accessory switched via F6
LD-G-30	AUX1	AUX2	---	---	Shunting gear on / off	Acceleration and braking delay on / off	---	---
LD-G-31	AUX1 (X7)	AUX2 (X8)	AUX3 (X3)	AUX4 (X6)			signal horn low (X1)	signal horn high (X2)
LD-G-32	AUX1	AUX2	---	---			---	---
LD-G-33	AUX1	AUX2	AUX3	AUX4			AUX5	AUX6
LD-G-34	AUX1	AUX2	AUX3	AUX4			AUX5	AUX6
LD-W-32	AUX1	AUX2	---	---			---	---
LD-W-33	AUX1	AUX2	AUX3	AUX4			AUX5	AUX6

If you want to use the decoder factory settings, you have to connect the lighting and the accessories according to the details in the list.

7. Programming the locomotive decoder

In DCC format it is possible to program register or configuration variables (CVs), main track programming can be used as well. In Motorola format the settings are saved in registers.

Programming with DCC central units

You can programm the configuration variables (CV) of the decoder from the digital central unit. See the chapter in the manual of your central unit where the byte wise programming of configuration variables (CVs) is explained. With central units that allow only register-programming it is only possible to program the variables CV#1, CV#2, CV#3, CV#4 and CV#29 (= register 1 to 5).

Programming with the Central Station and the Mobile Station

With the Central Station or the Mobile Station of Märklin** you can program the registers. With the auxillary register #62 values above 80 can be entered. Select the article no. 29750 from the locomotive database and program the decoder as described for this article in the Central Station´s or Mobile Station´s manual.

Programming with Motorola central units

Put the locomotive on a track oval or a track section connected to the central unit´s track output. Make sure no other vehicle than the one you intend to program is set on the track as the decoder inside this vehicle might be programmed as well.

Please note: If you use a central unit for both DCC and Motorola format it is recommended to program the decoder in the DCC format. After having finished programming the decoder it is possible to control it in Motorola format as well.

Reset the central unit (by simultaneously pushing the buttons "stop" and "go" for some time) or quickly switch the central unit off and on. First enter the current address or the address "80" (e.g. if you do not know the

current address). Manufacturers setting is "3". Set all functions (function, f1 to f4) to "off".

Push the "stop" button at the central unit. Next, operate the direction switch and hold it in that position while briefly pushing the "go" button. As soon as the lamps connected to the outputs AUX1 or AUX2 flash (after approx. 2 seconds) the decoder is in the programming mode and you can release the direction switch.

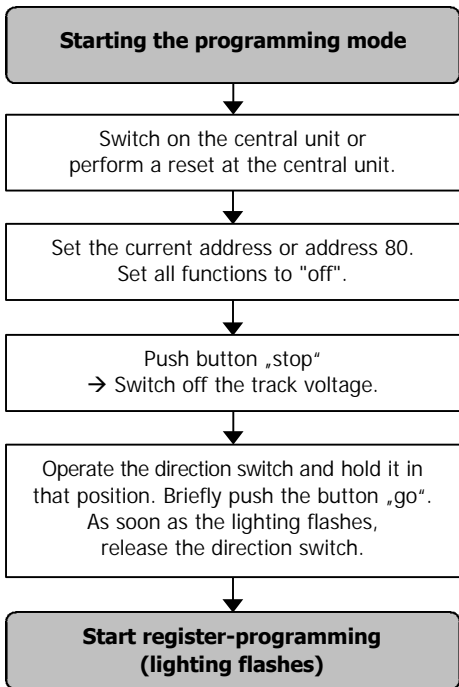

After having started the programming mode (and when the locomotive's lighting flashes) you can program the decoder's registers as follows:

1. Choose the register you want to program by setting the register's number like a Motorola locomotive address at your central unit. Please note that with some central units a leading "0" has to be entered.
2. Operate the direction switch. The lighting flashes faster.
3. Set the desired value of the register by setting the register's value as Motorola locomotive address at your central unit.
4. Operate the direction switch again. The lighting starts flashing again.

Repeat the steps 1 to 4 for all registers you want to program. In order to choose a register for programming or to enter a value for a register you have to confirm the entered number like selecting a Motorola locomotive address. The lighting shows which kind of entry the decoder expects:

- lighting flashes → entry of a CV's number
- lighting flashes faster → entry of a CV's value

In order to stop the programming mode push "stop".

Programming with the CV-Navi

Instead of programming the configuration variables or registers of the decoder using the digital central unit, you can use the free software CV-Navi. You will find the free download under:

www.tams-online.de

8. Configuration variables and registers

The following list shows all configuration variables (for the DCC format) and registers (for the Motorola format), that can be set for the locomotive decoders of the 30s series.

In the list you will find in the column "CV-no." the numbers of the configuration variables for programming in DCC format and in the column "Reg.-no." the numbers of the registers for programming in Motorola format. The defaults are those values set in the state of delivery and after a reset.

* For some configuration variables, the input values have to be calculated by adding the numerical values assigned to the desired parameters.

Name of CVs / Registers	CV-no.	Reg. no.	Input value (Default)	Remarks and Tips
Basic address	1	01	1 ... 255 (3)	Range of values in DCC-Format: 1 ... 127
Tip: If a value higher than 127 is set for the basic address and the use of extended addresses in CV#29 is set to off, the decoder does not react to signals in DCC format!				
Starting voltage	2	47	0 ... 255 (LD-G-30: 5) (LD-G-31: 5) (LD-G-32: 5) (LD-G-33: 5) (LD-G-34: 5) (LD-W-32: 50) (LD-W-33: 60)	= The voltage to be output to the motor at speed level 1. The value "0" corresponds to 0 Volt, the value "255" to the max. voltage. See "optimizing the driving characteristics" at the end of section 8., as well.

Name of CVs / Registers	CV-no.	Reg. no.	Input value (Default)	Remarks and Tips
Acceleration rate	3	44	0 ... 255 (LD-G-30 : 20) (LD-G-31 : 16) (LD-G-32 : 20) (LD-G-33 : 16) (LD-G-34 : 16) (LD-W-32 : 16) (LD-W-33 : 10)	= Length of the delay before the switching to the next higher speed level when the locomotive is accelerating. The delay is calculated as follows: (value of CV#3) x 0,9 sec. / number of speed levels
Braking rate	4	45	0 ... 255 (LD-G-30 : 15) (LD-G-31 : 8) (LD-G-32 : 15) (LD-G-33 : 8) (LD-G-34 : 8) (LD-W-32 : 5) (LD-W-33 : 5)	= Length of the delay before the switching to the next lower speed level when the locomotive is braking. The delay is calculated as described in CV#3.
Maximum voltage	5	46	0 ... 255 (0)	= The voltage to be output to the motor at the highest speed level. The value "2" corresponds to 0,8 %, the "255" to 100 % of the max. voltage. See "optimizing the driving characteristics" at the end of section 8., as well.

Name of CVs / Registers	CV-no.	Reg. no.	Input value (Default)	Remarks and Tips
-------------------------	--------	----------	-----------------------	------------------

Version	7	---	---	Read only in DCC format!
---------	---	-----	-----	--------------------------

Programming a SUSI module (LD-G-33, LD-G-34 and LD-W-33 only)	7	02	9	To start the programming of a CV of a SUSI module. The next CV set, is valid for the SUSI-module. The CV-no. is entered without a leading "9".
--	---	----	---	--

Example: Programming the CV#902 of the SUSI module to the value "8":
By entering the value "9" for CV#7 of the decoder, the programming mode is started. Next the CV of the SUSI module is chosen by entering a "2" or "02" (leaving out the leading "9") and for the CV#902 the value "8" is set. The decoder automatically goes back to the programming of it's own CVs. In order to programm another CV of the SUSI module, the operation has to be repeated completely.

Manufacturer	8	---	(62)	Read only in DCC format!
--------------	---	-----	------	--------------------------

Reset	8	03	0 ... 255	Any input value restores the settings in state of delivery.
-------	---	----	-----------	---

Motor frequency (LD-G-31, LD-G-33 and LD-G-34 only)	9	48	0, 1 (0)	Numerical value*	
				31,5 kHz	0
				17 kHz	1

Tip: In case that the locomotive's driving characteristics are not satisfactory with the standard setting of 31,5 kHz, the motor frequency of 17 kHz should be chosen.

Motor frequency (LD-W-32 only)	9	48	0, 1 (0)	Numerical value*	
				480 Hz	0
				60 Hz	1

Tip: In case that the locomotive's driving characteristics are not satisfactory with the standard setting of 480 Hz, the motor frequency of 60 Hz should be chosen.

Name of CVs / Registers	CV-no.	Reg. no.	Input value (Default)	Remarks and Tips
Analogue mode	12	06	0, 1	= procedure triggers a change of direction
			(LD-G-30 : 0)	Numerical value*
			(LD-G-31 : 1)	Overvoltage impulse (a.c. layouts) 0
			(LD-G-32 : 0)	Change of polarity (d.c. layouts) 1
Functions active in analogue mode (only for F1 to F8, not for F9 to F12)	13	41	0 ... 255 (0)	Numerical value*
			F1 on	1
			F2 on	2
			F3 on	4
			F4 on	8
			F5 on	16
			F6 on	32
			F7 on	64
F8 on	128			
Extended address	17	04	192 ... 255 (192)	Only for DCC format. Most central units permit entering extended addresses directly. The CVs # 17, 18 and 29 are set automatically to the proper values.
	18	05	0 ... 255 (255)	
Consistadresse	19	53	1 ... 127 (0)	= 2nd adress In DCC format only!

Name of CVs / Registers	CV-no.	Reg. no.	Input value (Default)	Remarks and Tips
Braking performance with d.c. voltage	27	49	0, 16, 32, 48 (0)	Numerical value*
				No braking with d.c. voltage 0
				Braking with posit. d.c. volt. 16
				Braking with negat. d.c. volt. 32
<p>Tip: It is standard to switch over into analogue mode when applying a d.c. voltage at the rails. In case that the decoder is run in a layout with a braking route based on applying a d.c. voltage (e.g. Märklin** -braking route), the locomotive has to be prevented from changing over into analogue mode and it has to be ensured that the locomotive reacts as expected on the braking route. When braking with positive or negative d.c. voltage is set for the decoder, the analogue recognition is switched off automatically. The setting of the negative or positive d.c. voltage is related to the right rail, as seen in the locomotive's direction of motion.</p>				
Configuration data 1	29	07	0 ... 64 (14)	Numerical value*
				Direction "Standard" 0
				Reverse direction 1
				14 speed levels 0
				28 or 128 speed levels 2
				Analoge recognition off 0
				Analoge recognition on 4
				RailCom off 0
				RailCom on 8
				Linear velocity characteristic 0
				Alternat. velocity charact. 16
Basic addresses 0				
Not for MM mode:			Extended addresses 32	
<p>Example: CV#29 = 0. → Direction = "Standard". 14 speed levels. RailCom = "off". Automatic analogue recognition = "off". Basic addresses.</p> <p>Example: CV#29 = 46. → Direction = "Standard". 28 or 128 speed levels in DCC-mode. Automatic analogue recognition = "on". RailCom = "on". Extended addresses.</p> <p>Tip: If the use of extended addresses is activated in CV#29, the decoder does not react to signals in Motorola format!</p>				

Name of CVs / Registers	CV-no.	Reg. no.	Input value (Default)	Remarks and Tips
Assignment of the function keys to the outputs (LD-G-30, LD-G-32, LD-W-32)				Numerical value* Assigned output:
F0 forward on	33	08	0 ... 3 (1)	AUX1 1
F0 backward on	34	09	0 ... 3 (2)	AUX2 2
F1	35	10	0 ... 3 (0)	
F2	36	11	0 ... 3 (0)	
F3	37	12	0 ... 3 (0)	
...		
F12	46	21	0 ... 3 (0)	
Factory settings: AUX1 to be switched with F0, switched on at forward motion. AUX2 to be switched with F0, switched on at backward motion. Example: AUX2 to be switched with F5 → CV#39 = 2 Example: AUX1 and AUX2 to be switched with F6 → CV#40 = 3 (= 1+2)				

Assignment of the function keys to the outputs (LD-G-31)				Numerical value* Assigned output:
F0 forward on	33	08	0 ... 63 (1)	AUX1 (X7) 1
F0 backward on	34	09	0 ... 63 (2)	AUX2 (X8) 2
F1	35	10	0 ... 63 (4)	AUX3 (X3) 4
F2	36	11	0 ... 63 (8)	AUX4 (X4) 8
F3	37	12	0 ... 63 (0)	low tone 16
F4	38	13	0 ... 63 (0)	high tone 32
F5	39	14	0 ... 63 (16)	
F6	40	15	0 ... 63 (32)	
F7	41	16	0 ... 63 (0)	
...		
F12	46	21	0 ... 63 (0)	
Factory settings: AUX1 to be switched with F0, switched on at forward motion. AUX2 to be switched with F0, switched on at backward motion. AUX3 to be switched with F1, AUX4 to be switched with F2, low tone signal horn to be switched with F5, high tone signal horn to be switched with F6. Example: AUX2 to be switched with F5 → CV#39 = 2 Example: AUX1 and AUX2 to be switched with F6 → CV#40 = 3 (= 1+2)				

Name of CVs / Registers	CV-no.	Reg. no.	Input value (Default)	Remarks and Tips
-------------------------	--------	----------	-----------------------	------------------

Assignment of the function keys to the outputs (LD-G-33, LD-G-34, LD-W-33)				Numerical value*	
				Assigned output:	
F0 forward on	33	08	0 ... 63 (1)	AUX1	1
F0 backward on	34	09	0 ... 63 (2)	AUX2	2
F1	35	10	0 ... 63 (4)	AUX3	4
F2	36	11	0 ... 63 (8)	AUX4	8
F3	37	12	0 ... 63 (0)	AUX5	16
F4	38	13	0 ... 63 (0)	AUX6	32
F5	39	14	0 ... 63 (16)		
F6	40	15	0 ... 63 (32)		
F7	41	16	0 ... 63 (0)		
...			
F12	46	21	0 ... 63 (0)		

Factory settings: AUX1 to be switched with F0, switched on at forward motion. AUX2 to be switched with F0, switched on at backward motion. AUX3 to be switched with F1, AUX4 to be switched with F2, AUX5 to be switched with F5, AUX6 to be switched with F6.

Example: AUX2 to be switched with F5 → CV#39 = 2

Example: AUX1 and AUX2 to be switched with F6 → CV#40 = 3 (= 1+2)

Extended kickfunction (LD-G-31)	47	50	0 ... 63 (0)	Numerical value*	
				for AUX1 (X7)	1
				for AUX2 (X8)	2
				for AUX3 (X3)	4
				for AUX4 (X4)	8

When setting the extended kick function for an output, the motor is supplied with power as long as the kick function is switched on.

Example of use: When switching an output via the extended kick function the locomotive runs automatically a little bit nearer to the carriage (in order to ease the burden from the coupling). Afterwards the electric coupling is released via the kick function and the locomotive moves away automatically from the uncoupled carriage.

Name of CVs / Registers	CV-no.	Reg. no.	Input value (Default)	Remarks and Tips	
Extended kickfunction (LD-G-33, LD-G-34 und LD-W-33)	47	50	0 ... 63 (0)	Numerical value*	
				for AUX 1	1
				for AUX 2	2
				for AUX 3	4
				for AUX 4	8
				for AUX 5	16
				for AUX 6	32
<p>When setting the extended kick function for an output, the motor is supplied with power as long as the kick function is switched on. Example of use: When switching an output via the extended kick function the locomotive runs automatically a little bit nearer to the carriage (in order to ease the burden from the coupling). Afterwards the electric coupling is released via the kick function and the locomotive moves away automatically from the uncoupled carriage.</p>					
Voltage at extended kick function (LD-G-31,-33,-34, LD-W-33)	48	51	0 ... 255 (0)	= voltage applied to the motor when switching an output via the extended kick function.	
Configuration data 2	49	22	0 ... 127 (73)	Numerical value*	
				Load control inactive	0
				LD-G-decoders only: Load control active	1
				Shunting gear at F1	2
				Shunting gear at F2	4
				Shunting gear at F3	8
				Shunting gear at F4	16
				Acceleration and brake delay to be switched at F3	32
				Acceleration and brake delay to be switched at F4	64
Emergency stop at change of direction	128				

Name of CVs / Registers	CV-no.	Reg. no.	Input value (Default)	Remarks and Tips
Parameter of load control KP (LD-G-decoders only)	50	23	0 ... 255 (LD-G-30 : 40) (LD-G-31 : 65) (LD-G-32 : 90) (LD-G-33 : 80) (LD-G-34 : 80)	= Proportional component of the load control. See "optimizing the driving characteristics" at the end of section 8., as well.
The parameter KP defines the basic speed. A too small value → locomotive too slow. A too high value → heavy shaking of the locomotive.				
Parameter of load control KI (LD-G-decoders only)	51	24	0 ... 255 (LD-G-30 : 30) (LD-G-31 : 12) (LD-G-32 : 70) (LD-G-33 : 45) (LD-G-34 : 45)	= Integral component of the load control. See "optimizing the driving characteristics" at the end of section 8., as well.
The parameter KI provides the fine tuning of the load control. The value has to be adjusted in very small steps. A too high value → heavy shaking of the locomotive.				
Parameter of load control KD (LD-G-decoders only)	52	25	0 ... 255 (LD-G-30 : 40) (LD-G-31 : 40) (LD-G-32 : 40) (LD-G-33 : 50) (LD-G-34 : 50)	= Differential component of the load control. See "optimizing the driving characteristics" at the end of section 8., as well.
The parameter KD retards the transforming of the load control. A too small value → shaking of the locomotive. A too high value → vibrating of the locomotive.				

Name of CVs / Registers	CV-no.	Reg. no.	Input value (Default)	Remarks and Tips
Effects of the outputs				Numerical value*
AUX1	53	26	0 ... 255 (0)	Independent of direction 0
AUX2	54	27	0 ... 255 (0)	AUX off at backward motion 1
LD-G-31, LD-G-33, LD-G-34, LD-W-33 only:				AUX off at forward motion 2
AUX3	55	28	0 ... 255 (0)	For AUX6 only: slider commutation 4
AUX4	56	29	0 ... 255 (0)	
LD-G-33, LD-G-34, LD-W-33 only:				Flashing inverted 8
AUX5	57	30	0 ... 255 (0)	Keying ratio of the flash lights: Lighting off 16, 32, 48, 64, 80, 96, 112 Regular flashing 128 144, 160, 176, 192, 208, 224 Permanent light 240
AUX6	58	31	0 ... 255 (0)	
Example: Regular flashing at AUX1 and lighting off at forward motion → CV#53 = 130 (= 128 + 2)				
Tip: The keying ratio for the flash lights determines the phase length of the on-/off states of the lighting.				

Kicking time LD-G-31, LD-G-33, LD-G-34, LD-W-33 only:				= length of time the full voltage is applied, before being reduced. The max. time of 20 seconds corresponds to the value "15".
AUX1, AUX2	59	32	0 ... 255 (0)	
AUX3, AUX4	60	33	0 ... 255 (0)	
LD-G-33, LD-G-34, LD-W-33 only:				
AUX5, AUX6	61	34	0 ... 255 (0)	
It is possible to choose a value between 0 and 15 for any of the outputs. For the outputs with an odd number the value is set directly, for the outputs with an even number the input value has to be multiplied by 16. Example: For AUX3 value "7" and for AUX4 value "3" → Input value: 55 (= 7 + 3x16)				

Name of CVs / Registers	CV-no.	Reg. no.	Input value (Default)	Remarks and Tips
-------------------------	--------	----------	-----------------------	------------------

Dimming of the outputs:				= Reduction of the voltage applied to the output. The value "1" corresponds to the lowest, "15" to the maximum voltage.
AUX1, AUX2	62	35	1...255 (255)	
LD-G-31, LD-G-33, LD-G-34, LD-W-33 only:				
AUX3, AUX4	63	36	1...255 (255)	
LD-G-33, LD-G-34, LD-W-33 only:				
AUX5, AUX6	64	37	1...255 (255)	
It is possible to choose a value between 0 and 15 for any of the outputs. For the outputs with an odd number the value is set directly, for the outputs with an even number the input value has to be multiplied by 16. Example: For AUX5 value "14" and for AUX6 value "2" → input value: 46 (=14 + 2x16)				

Starting-kick	65	60	0 ... 14 (LD-G-30 : 0) (LD-G-31 : 2) (LD-G-32 : 0) (LD-G-33 : 0) (LD-G-34 : 0) (LD-W-32 : 55) (LD-W-33 : 65)	= short-time increase of motor voltage while starting to clear the breakaway torque.
---------------	----	----	---	--

Example: CV#65 = 6 → The motor voltage while starting is equivalent to the voltage applied in operation at speed level 6. It is reduced immediately to the set speed level with the braking rate defined in CV#4. Thus, when altering the value for CV#4 it may be necessary to alter CV#65, too.

Name of CVs / Registers	CV-no.	Reg. no.	Input value (Default)	Remarks and Tips
Alternative velocity characteristic (only with mode 28 speed levels)	67 . . 94	67 . . 94	0 ... 255	= The velocity table for the alternative velocity characteristic. Any motor voltage can be assigned to all of the 28 speed levels. The value "0" corresponds to a voltage of "0", "255" to the maximum voltage.
Flashing frequency of the lighting	112	38	10 ... 255 (200)	Settings common for all lighting.
				10 → lowest frequency
				255 → highest frequency
Examples for the flashing frequency: CV#112 = 10 → 0,125 Hz / CV#112 = 200 → 0,5 Hz CV#112 = 230 → 1 Hz / CV#112 = 255 → 2,5 Hz				
Internal speed level for CV#116	113	39	1 ... 126 (16)	= speed level, at which the outputs defined in CV#116 are dimmed.
2nd Motorola address	114	40	1 ... 255 (4)	= Address needed to switch additional functions in Motorola format. The function keys F5 to F8 are reached via the function keys F1 to F4, the function key F9 via the function key F0.

Name of CVs / Registers	CV-no.	Reg. no.	Input value (Default)	Remarks and Tips	
Shunting light	115	42	0 ... 255 (0)	Numerical value*	
				Shunting light for AUX1	1
				Shunting light for AUX2	2
				Shunting light to be switched with F3	64
				Shunting light to be switched with F4	128
				LD-G-31, LD-G-33, LD-G-34 and LD-W-33 only:	
				Shunting light for AUX3	4
				Shunting light for AUX4	8
				LD-G-33, LD-G-34, LD-W-33 only:	
				Shunting light for AUX5	16
				Shunting light for AUX6	32
Example: For AUX2 and AUX 3 shunting light, to be switched with F4: → input value: 134 (= 2 + 4 + 128)					
Dimming depending on the speed level	116	43	0 ... 63 (0)	Determines which outputs have to be dimmed from the speed level defined in CV#113.	
				Numerical value*	
				AUX1	1
				AUX2	2
				LD-G-31, LD-G-33, LD-G-34 and LD-W-33 only:	
				AUX3	4
				AUX4	8
				LD-G-33, LD-G-34, LD-W-33 only:	
				AUX5	16
				AUX6	32

Name of CVs / Registers	CV-no.	Reg. no.	Input value (Default)	Remarks and Tips
Switching off at overload (LD-G-30 and LD-G-33 only)	117	52	0...255 (LD-G-30 : 64) (LD-G-33 : 69)	Determines, at which current the overload protection responds. With the LD-G-30 the value 64 corresponds to 700 mA, with the LD-G-33 the value 69 corresponds to 1,5 A.

Caution: A total current of more than 700 mA or 1,5 A can lead to damage of the decoder due to overload. When for CV#117 a higher value than the default value is set, the overload protection is not guaranteed.

Alternative dimming of the outputs:				= reduction of the voltage applied to the output. The value "1" corresponds to the minimum, "15" to the max. voltage. The values are only valid for the outputs defined in CV#116 and for the speed level defined in CV#113.
AUX1, AUX2	118	54	1...255 (255)	
LD-G-31, LD-G-33, LD-G-34, LD-W-33 only:				
AUX3, AUX4	119	55	1...255 (255)	
LD-G-33, LD-G-34, LD-W-33 only:				
AUX5 / AUX6	120	56	1...255 (255)	

It is possible to choose a value between 0 and 15 for any of the outputs. For the outputs with an odd number the value is set directly, for the outputs with an even number the input value has to be multiplied by 16.

Example:

For AUX5 value "14" and for AUX6 value "2" → input value: 46 (=14 + 2x16)

Name of CVs / Registers	CV-no.	Reg. no.	Input value (Default)	Remarks and Tips	
Switching off function F0 at speed level 0 (LD-G-31, LD-G-33, LD-G-34 and LD-W-33 only)	121	57	0...255 (0)	Determines the functions (F1 to F8) to switch off the function F0 at speed level 0.	
				Numerical value*	
				F1	1
				F2	2
				F3	4
				F4	8
				F5	16
				F6	32
				F7	64
F8	128				
Switching on the outputs at speed level 0 (LD-G-31, LD-G-33, LD-G-34 and LD-W-33 only)	122	58	0...63 (0)	Determines the outputs to be switched on via the functions defined in CV#121 at speed level 0.	
				Numerical value*	
				AUX1	1
				AUX2	2
				AUX3	4
				AUX4	8
				AUX5	16
AUX6	32				

Name of CVs / Registers	CV-no.	Reg. no.	Input value (Default)	Remarks and Tips	
Switching off functions at speed level 0 (LD-G-31, LD-G-33, LD-G-34 and LD-W-33 only)	123	59	0...15 (0)	Determines the function buttons to be switched off at the function defined in CV#121.	
				Numerical value*	
				F1	1
				F2	2
				F3	4
F4	8				
Optimising the load control	124	61	1...15 (LD-G-30: 3) (LD-G-31: 9) (LD-G-32: 2) (LD-G-33: 2) (LD-G-34: 2)	To adjust the load control to the individual motor voltage. See "optimizing the driving characteristics" at the end of section 8., as well.	
The value for CV#124 has to be altered when the velocity does not increase with the high speed levels. Alter the value for CV#124 step by step until the highest velocity has just been reached at the highest speed level.					
Auxiliary register for programming with MM central units	---	62	0...64 (0)	To enable the input of values > 80 with central units allowing the input of values between 0 and 80 only.	
The value set in register #62 multiplied by 4 is added to the value of the register to be programmed. Example for inputting the value 137 into register #09:					
<ol style="list-style-type: none"> 1. $137 / 4 = 34$, remainder 1 2. Programming for register #62 the value 34. 3. Programming for register #09 the value 1. 					

Name of CVs / Registers	CV-no.	Reg. no.	Input value (Default)	Remarks and Tips			
Inverting the outputs AUX1 - AUX2 (LD-G-31 only)	126	64	1...255 (0)	Instead of switching on the output with function key "on" and off with function key "off" the output is switched on with "off" and off with "on".			
				Numerical value*			
				For forwards motion:	AUX1 inverted	1	
					AUX2 inverted	2	
					AUX3 inverted	4	
					AUX4 inverted	8	
				For backwards motion:	AUX1 inverted	16	
					AUX2 inverted	32	
					AUX3 inverted	64	
					AUX4 inverted	128	
Inverting the outputs AUX1 to AUX6 (LD-G-33, LD-G-34 and LD-W-33 only)	126	(64)	1...63 (0)	Instead of switching on the output with function key "on" and off with function key "off" the output is switched on with "off" and off with "on".			
				Numerical value*			
				AUX1 inverted	1		
				AUX2 inverted	2		
				AUX3 inverted	4		
				AUX4 inverted	8		
				AUX5 inverted	16		
				AUX6 inverted	32		

Optimising the CV-settings

Above all, the driving characteristics can be influenced by setting the CV#2 (starting voltage) and CV#5 (maximum voltage) and for the decoders for d.c.motors (LD-G-versions), in addition, by setting the CV#124 (optimizing the load control) and the CV#50 to #52 (parameters of the load control).

Make the setting for the load controlled decoders (LD-G-decoders) in the following order, as far as required:

1. CV#124
2. CV#50 to #52
3. CV#2 and CV#5

To adjust the parameters for the load control (CV#50 to #52) the following procedure is recommended:

If the locomotive is shaking: → Increase the value for CV#52 (KD) in 5-steps. If this does not lead to an improvement of the driving characteristics, set the value of CV#52 back to factory setting (default value). Then decrease the value for CV#50 (KP) in 5-steps and for CV#51 (KI) in 2-steps.

If the locomotive does not have enough power and e.g. gets very slow on the way uphill: → Increase the value for CV#51 (KI) in 2-steps, until the locomotive starts to shake. Then increase the value for CV#52 (KD) in 5-steps. If this does not lead to an improvement or the locomotive starts to shake immediately after increasing CV#51, set the values for CV#51 and CV#52 back to factory setting (default value) and increase the value for CV#50 (KP) in 5-steps.

If the locomotive is shaking heavily: → Decrease the value for CV#52 in 5-steps.

9. Check list for trouble shooting

- Parts are getting very hot and/or start to smoke.



Disconnect the system from the mains immediately!

Possible cause: one or more connections are soldered incorrectly.

→ Check the connections.

Possible cause: Short circuit. The decoder is connected to locomotive or carriage ground. → Check the connections. A short circuit can result in irreparable damage.

Possible cause: The connection of the motor is connected to locomotive ground. → Disconnect the connection from locomotive ground.

- After programming the decoder the locomotive does not run or runs badly.

Possible cause: The set values for the CV are inconsistent.

→ Perform a decoder reset and program the decoder anew.

- In digital mode the locomotive suddenly runs very fast.

Possible cause: Interfering signals from the layout have switched the decoder to analogue mode. → As the origin of the interfering signals often cannot be found, it is advisable to switch off the automatic recognition of the analogue mode during digital operation.

- An output cannot be switched on.

Possible cause: The values set in CV#53 to 58 for an output, contradict one another. → Alter the values for CV#53 to 58.

- The locomotive does not run in analogue mode.

Possible cause: The analogue mode is switched off. → Alter the value for CV#29.

- The CV values cannot be read out by RailCom.

Possible cause: RailCom is switched off. → Alter the value of CV#29.

- The lighting goes on and off when the speed levels are turned up or the lighting cannot be switched on or off.

Possible cause: The speed mode of the decoder and the digital control unit do not correspond. Example: The central is set to the mode 28 speed levels, but the decoder to the mode 14 speed levels. → Change the speed mode at the central and / or at the decoder.

- LD-G-30, LD-G-33 and LD-G-34 only: The decoder switches off in operation, switches on after a short time and switches off again immediately.

Possible cause: The overload protection was activated, as the current consumption exceeds the decoder's maximum total current. → Check the current consumption of the motor and the accessories. Possibly the decoder is not suitable for being mounted in this locomotive.

If you cannot find the problem, please return the decoder for repair (address on the cover page).

10. CE and warranty

Certification (CE)

This product is developed and tested in accordance with the European standards EN 55014-1 and EN 61000-6-3. This product conforms with the EC- directive 2004/108/EG on electromagnetic radiation and is therefore CE certified.

To guarantee the electromagnetic tolerance in operation you must take the following precautions:

- Connect the transformer only to an approved mains socket installed by an authorised electrician.
- Make no changes to the original parts and accurately follow the instructions, circuit diagram and PCB layout included with this manual.
- Use only original spare parts if you have to repair the decoder.

Conditions of warranty

This product is guaranteed for two years. The warranty includes the correction of faults which can be proved to be due to material failure or factory flaw. We guarantee the adherence to the technical specifications of the circuit when assembled and connected according to the manual.

Other claims are excluded. By law, we are not responsible for damages or secondary damages in connection with this product. We retain the right to repair, make improvements, supply spare parts or return the purchase price.

The following invalidate the warranty:

- using an unsuitable soldering iron, solder containing liquid acids or similar,
- if damage is caused by not following the instructions in this manual, if the decoder has been altered and repair attempts have failed,
- if arbitrary changes in the circuit are made,
- if additional components are added which are not described in the manual,
- if the copper tracks or soldering eyes are damaged,
- if damage occurs due to an overload of the decoder,
- if connected to a incorrect voltage or current,
- if damaged by other persons,
- if damaged by faulty operation or if damaged by careless use or abuse,
- if damaged by touching components before electrostatic discharging of the hands.

The asterisks **

This manual mentions the following companies:

Gebr. MÄRKLIN** & Cie. GmbH

Postfach 8 60, D-73008 Göppingen

LD-G-30:

Anschlüsse – Connections – Connexions – Aansluiten

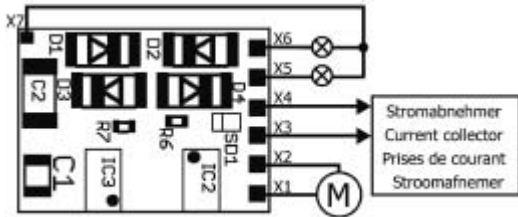

ODER – OR – OU - OF:

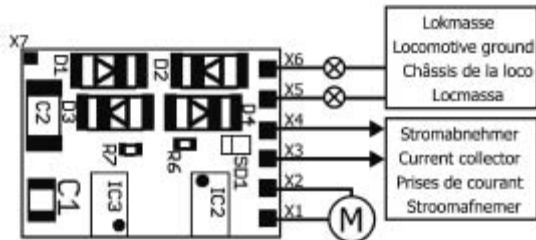

X1	orange / orange / orange / oranje: Motoranschluß 1 / Motor connection 1 Connexion moteur 1 / Motoraansluiting 1
X2	grau / grey / gris / grijs: Motoranschluß 2 / Motor connection 2 Connexion moteur 2 / Motoraansluiting 2
X3	rot / red / rouge / rood: Schienenabnehmer rechts / Current collector right side Frotteur droite / Stroomafnemer rechterhand
X4	schwarz / black / noir / zwart: Schienenabnehmer links / Current collector left side Frotteur gauche / Stroomafnemer linkerhand
AUX1 (X5)	weiß / white / blanc / wit: Beleuchtung vorne / Front lighting Feux avant / Verlichting voor oder / or / ou / of: Beliebiger Verbraucher / Optional accessory Consommateur quelconque / Gewenste verbruiker (max. 100 mA)
AUX2 (X6)	gelb / yellow / jaune / geel: Beleuchtung hinten / Back lighting Feux arrière / Verlichting achter oder / or / ou / of: Beliebiger Verbraucher / Optional accessory Consommateur quelconque / Gewenste verbruiker (max. 100 mA)
RL (X7)	Rückleiter für alle Funktionen Return conductor for all functions Pole commun des fonctions Retourleiding voor alle functies

LD-G-31: Anschlüsse – Connections – Connexions – Aansluiten

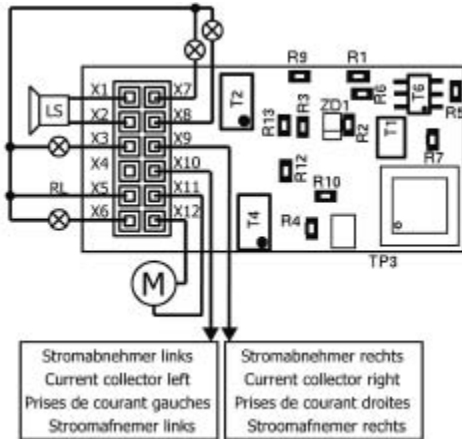

ODER:
OR:
OU:
OF:

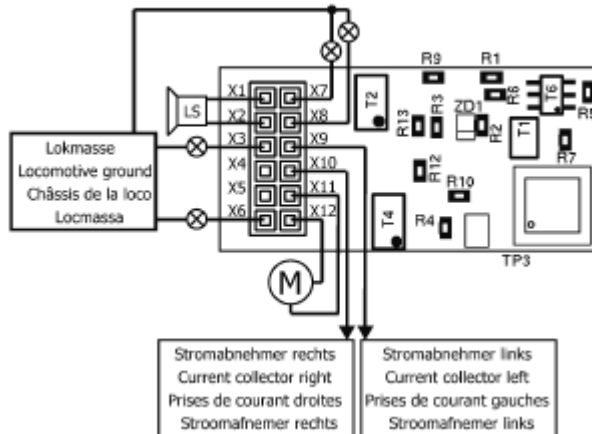

X1	Lautsprecher Anschluss 1 / Loudspeaker connection 1 Connexion haut-parleur 1 / Luidspreeker aansluiting 1
X2	Lautsprecher Anschluss 2 / Loudspeaker connection 2 Connexion haut-parleur 2 / Luidspreeker aansluiting 2
AUX3 (X3)	Beliebiger Verbraucher / Optional accessory (max. 300 mA) Consommateur quelconque / Gewenste verbruiker (max. 300 mA)
X4	frei / open / libre / vrij
RL (X5)	Rückleiter für alle Funktionen Return conductor for all functions Pole commun des fonctions retourleiding voor alle functies
AUX4 (X6)	Beliebiger Verbraucher / Optional accessory (max. 300 mA) Consommateur quelconque / Gewenste verbruiker (max. 300 mA)
AUX1 (X7)	Beleuchtung vorne / Front lighting (max. 300 mA) Feux avant / Verlichting voor (max. 300 mA)
AUX2 (X8)	Beleuchtung hinten / Back lighting (max. 300 mA) feux arrière / Verlichting achter (max. 300 mA)
X9	Schienenabnehmer links / Current collector left side Frotteur gauche / Stroomafnemer linkerhand
X10	Schienenabnehmer rechts / Current collector right side Frotteur droite / Stroomafnemer rechterhand
X11	Motoranschluß 1 / Motor connection 1 Connexion moteur 1 / Motoraansluiting 1
X12	Motoranschluß 2 / Motor connection 2 Connexion moteur 2 / Motoraansluiting 2

LD-G-32: Anschlüsse – Connections – Connexions – Aansluiten

- * Stützkondensator, falls erforderlich
- * Smoothing capacitor, if necessary
- * Condensateur si necessaire
- * Ondersteuningscondensator, indien noodzakelijk

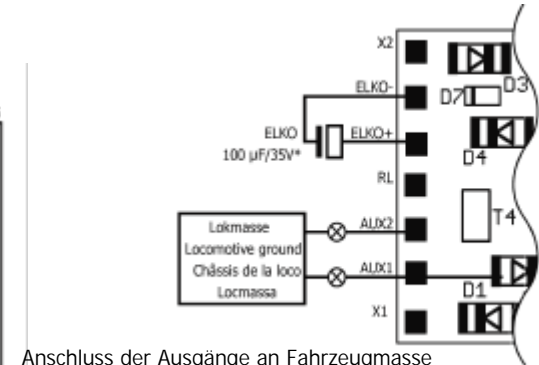
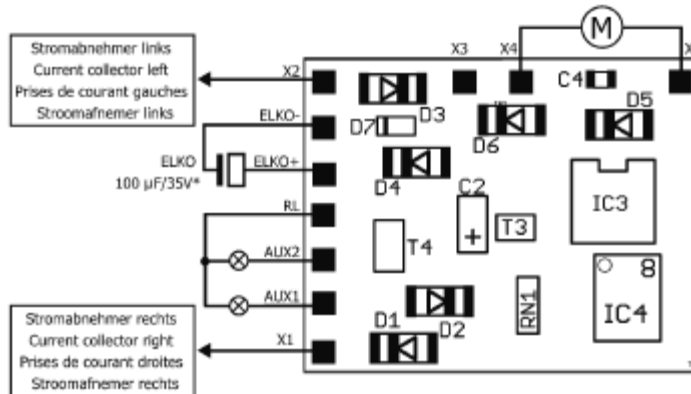

Anschluss der Ausgänge an Fahrzeugmasse
 Connection of the outputs to vehicle ground
 Raccordement des sorties via la masse du vehicule
 Verbinding van de uitgangen met de voortuigmassa

LD-W-32: Anschlüsse – Connections – Connexions – Aansluiten

- * Stützkondensator, falls erforderlich
- * Smoothing capacitor, if necessary
- * Condensateur si necessaire
- * Ondersteuningscondensator, indien noodzakelijk

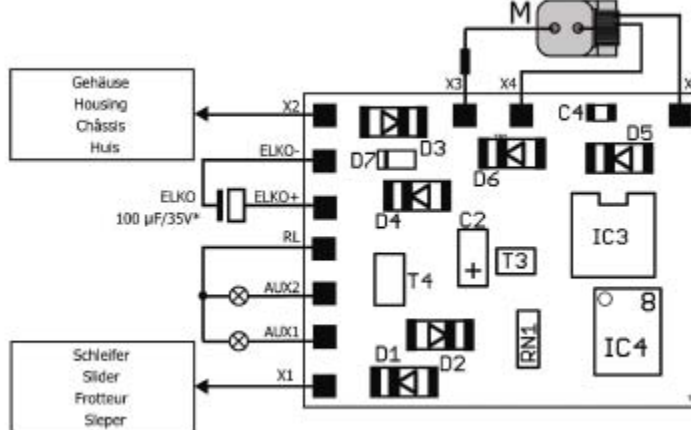

AUX1 – AUX2	Ausgänge (max. 300 mA) Outputs (max. 300 mA) Sorties (max. 300 mA) Uitgangen (max. 300 mA)
RL	Rückleiter für alle Funktionen Return conductor for all functions Pole commun des fonctions Retourleiding voor alle functie
X1	Schienenabnehmer rechts Rail current collectors right Prises de courant de la voie droites Railstroomafnemers rechts
X2	Schienenabnehmer links Rail current collectors left Prises de courant de la voie gauches Railstroomafnemers links
X3 / X4 / X5	Motor / Moteur

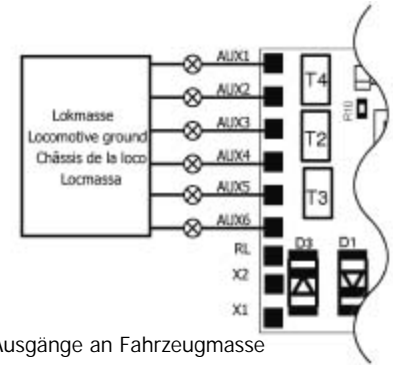
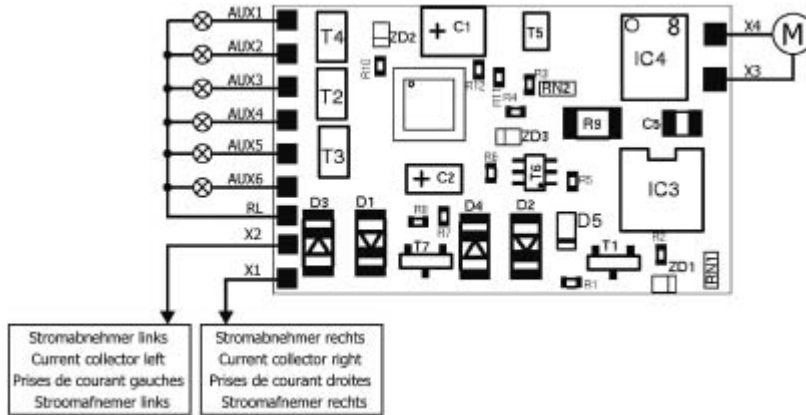
LD-G-33: Anschlüsse – Connections – Connexions – Aansluiten

Anschluss der Ausgänge an Fahrzeugmasse
Connection of the outputs to vehicle ground
Raccordement des sorties via la masse du véhicule
Verbinding van de uitgangen met de voortuigmasse

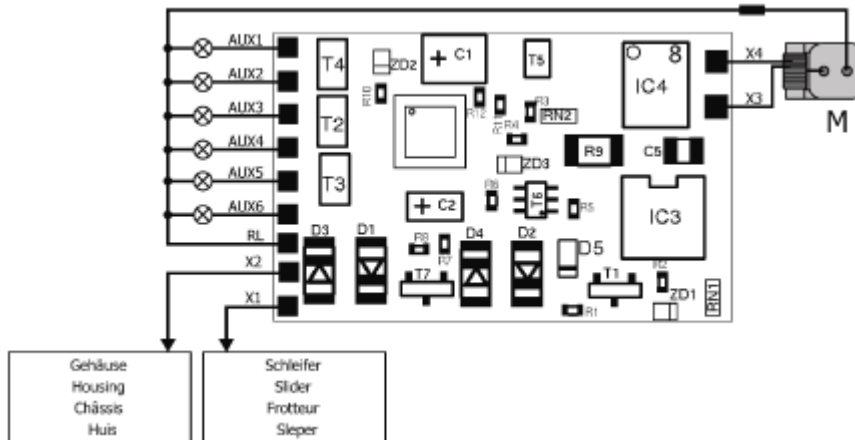
LD-W-33: Anschlüsse – Connections – Connexions – Aansluiten

AUX1 – AUX6	Ausgänge (max. 500 mA) Outputs (max. 500 mA) Sorties (max. 500 mA) Uitgangen (max. 500 mA)
RL	Rückleiter für alle Funktionen Return conductor for all functions Pole commun des fonctions Retourleiding voor alle functie
X1	Schienenabnehmer rechts Rail current collectors right Prises de courant de la voie droites Railstroomafnemers rechts
X2	Schienenabnehmer links Rail current collectors left Prises de courant de la voie gauches Railstroomafnemers links
X3 / X4	Motor / Moteur

LD-G-34: Anschlüsse – Connections – Connexions – Aansluiten

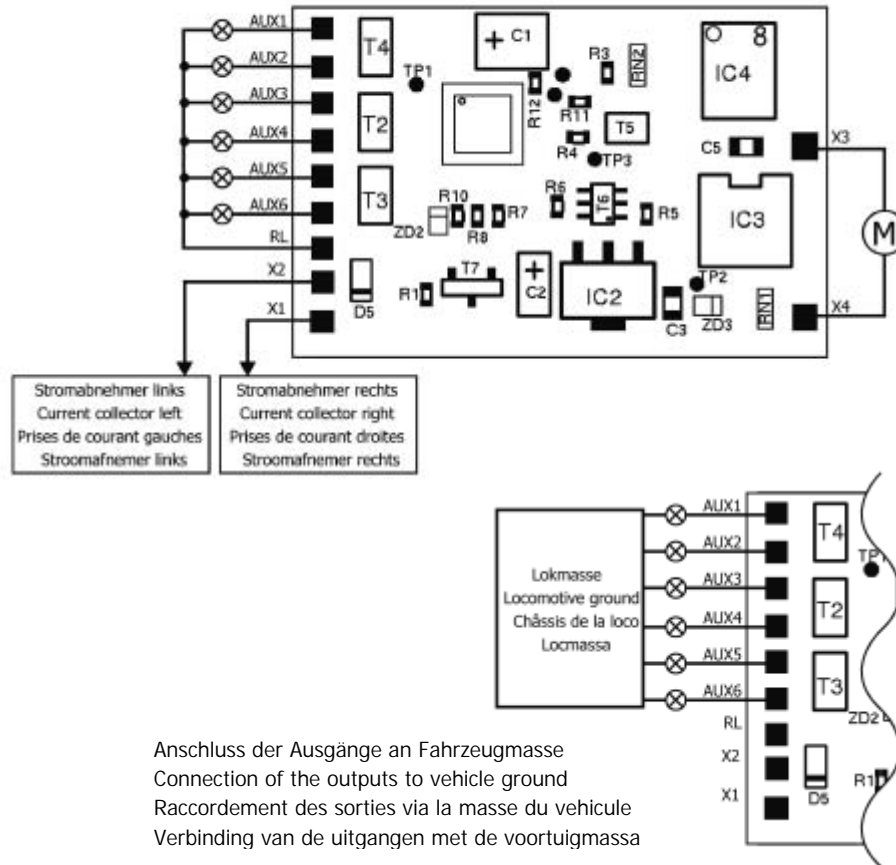

AUX1 – AUX6	Ausgänge (max. 500 mA) Outputs (max. 500 mA) Sorties (max. 500 mA) Uitgangen (max. 500 mA)
RL	Rückleiter für alle Funktionen Return conductor for all functions Pole commun des fonctions Retourleiding voor alle functie
X1	Schienenabnehmer links Rail current collectors left Prises de courant de la voie gauches Railstroomafnemers links
X2	Schienenabnehmer rechts Rail current collectors right Prises de courant de la voie droites Railstroomafnemers rechts
X3 / X4	Motor / Moteur

LD-G-33 / LD-W-33:

Anschluss eines SUSI-Moduls
und eines Stützelkos

Connecting a SUSI-module and
a smoothing capacitor

Connexion d'un module SUSI
et d'un condensateur

Aansluiten van een SUSI-module
en een ondersteuningscondensator

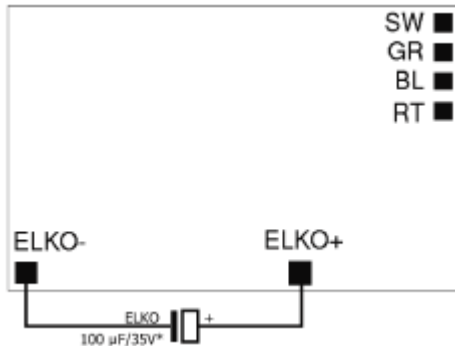
**LD-G-34:**

Anschluss eines SUSI-Moduls
und eines Stützelkos

Connecting a SUSI-module and
a smoothing capacitor

Connexion d'un module SUSI
et d'un condensateur

Aansluiten van een SUSI-module
en een ondersteuningscondensator

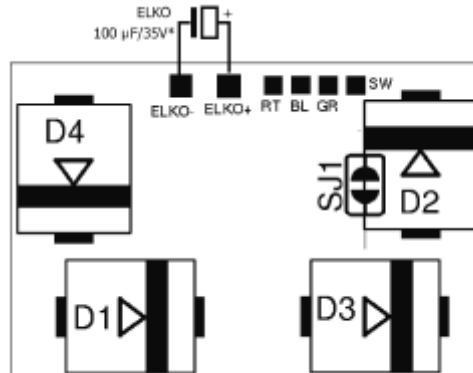

SW	SUSI – GND (schwarz – black – noir – zwaart)
GR	SUSI – DATA (grau – grey – gris – grijs)
BL	SUSI – CLK (blau – blue – bleu – blauw)
RT	SUSI – PLUS (rot – red – rouge – rood)
*	Stützkondensator, falls erforderlich Smoothing capacitor, if necessary Condensateur si necessaire Ondersteuningscondensator, indien noodzakelijk

Information and tips:
Informations et conseils:

<http://www.tams-online.de>

Warranty and service:
Garantie et service:

Tams Elektronik GmbH

Rupsteinstraße 10
D-30625 Hannover

fon: +49 (0)511 / 55 60 60

fax: +49 (0)511 / 55 61 61

e-mail: modellbahn@tams-online.de



DE 37847206

